

P.C. MOUNTING

▲ O.P. (MM)	P.T. (MM)
6.8 ± 0.5	1.8 MAX.

O.P. = OPERATING POINT  
P.T. = PER-TRAVEL

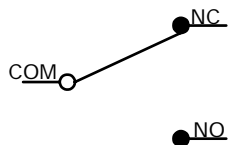

CIRCUIT: SPDT

NOTES:

1. ALL DIMENSIONS IN MM [INCH]
2. GENERAL TOLERANCE: X.X=± 0.4  
X.XX=± 0.25
- ▲3. RATING: 1A @125VAC UL, CSA APPROVED
- ▲4. OPERATING FORCE: 15± 5 GRAMS
5. OPERATING TEMP: -25°C TO 85°C
6. ELECTRICAL LIFE: 300,000 CYCLES MIN.
7. INSULATION RESISTANCE: 100 MEGA-OHMS
8. DIELECTRIC STRENGTH: 1000V RMS AT SEA LEVEL
9. ▲ DENOTES CRITICAL PARAMETER.
10. 2002/95/EC (ROHS) COMPLIANT
11. CONTACT MATERIAL SILVER

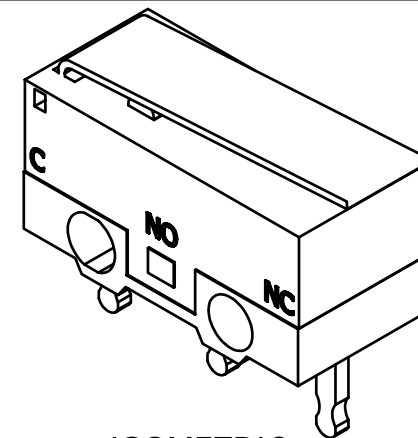
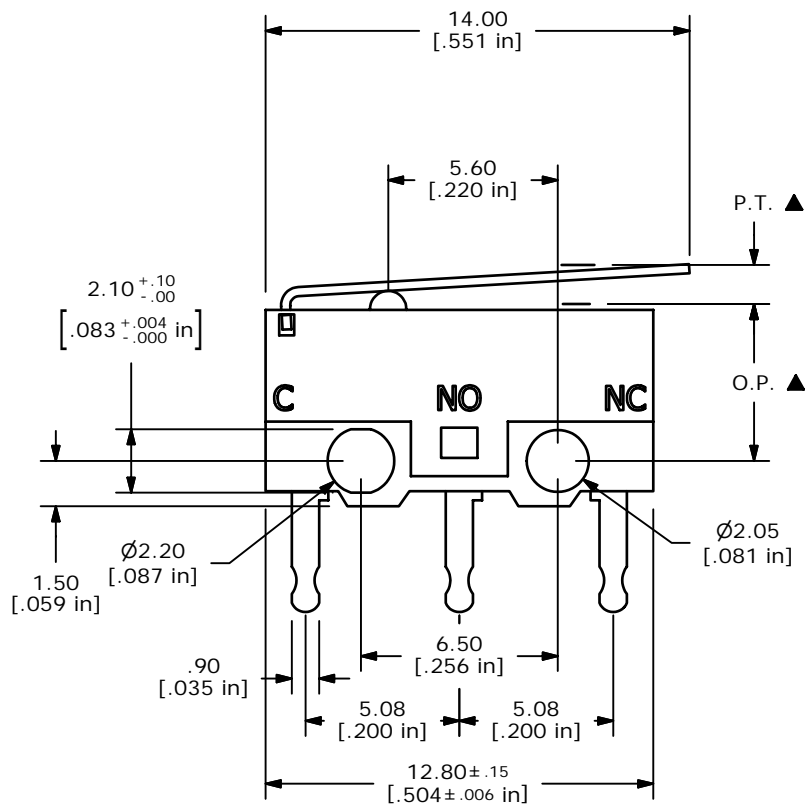

ISOMETRIC

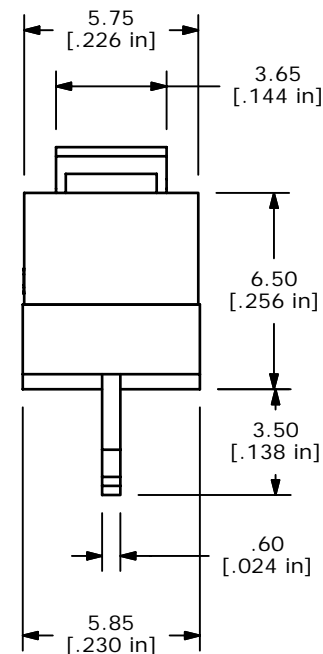

TITLE DM0850101F015P1A

B	17478	REVISED AND REDRAWN	7/17/07	BF
REV	PCR NO	DESCRIPTION	DATE	BY

THE INFORMATION CONTAINED IN THIS DOCUMENT IS PROPRIETARY TO E-SWITCH AND IS NOT TO BE COPIED OR TRANSFERRED

SCALE	DATE	DR	DWG	REV
4:1	7/17/2007	BF	P030006	B